

## HG18 Donut Glazers

Belshaw's HG18 glazers allow fast, uniform glazing of donuts, cinnamon rolls and other baked goods. These glazers conveniently glaze one full 17" x 25" screen at a time with minimal waste.

Glazers are movable on casters and require little space. A bottom shelf provides storage space for screens and a glaze bucket. A drain valve allows left over glaze to be poured out back into a glaze bucket. Stainless steel construction and sound design facilitate cleaning and provide a durable product that will stand up to years of everyday use.

The EZlift method employed by the HG18EZ glazer eliminates the lifting associated with standard hand glazers. Rather than being carried by the operator, the glaze applicator slides along rails, and tilts down to fill up with glaze. This design provides good glaze coverage with little strain on the operator.

### STANDARD ITEM NUMBERS

- **HG18C** Item # 22526
- **HG18EZ** Item # 22529

### STANDARD FEATURES

- Glazes a 17" x 25" screen of donuts (2 dozen at once)
- **HG18C** glaze applicator is a clamshell opening design to control flow of glaze. Operator lifts the glaze applicator manually.
- **HG18EZ** glaze applicator slides on rails. Operator does not lift the glaze applicator manually.
- Drain tray is supplied on all models.
- Drain returns unused glaze to a bucket for later use.
- Stainless steel construction throughout.
- 4" heavy duty water-resistant casters (2 lockable).
- Washable in rack washer or by hose down with brush.
- Certified to NSF-2.



WWW

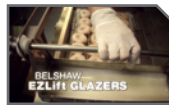

VIDEO



**HG18C** Donut Glazer \*Glazing screens supplied separately



**HG18EZ** Donut Glazer \*Glazing screens supplied separately



**HG18EZ** EZLift glaze applicator (slides on rails)



**HG18C** Clamshell glaze applicator (handheld)



**HG18EZ** EZLift operation

DIAGRAM SHOWS HG18EZ GLAZER.  
HG18C GLAZER HAS SAME DIMENSIONS,  
EXCEPT 34" (86 CM) HEIGHT

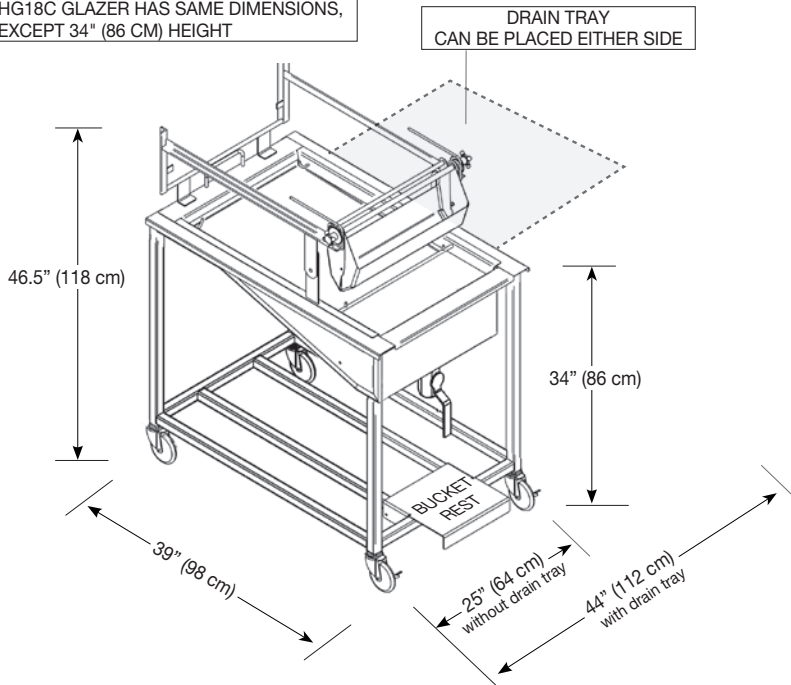

**DIMENSIONS**

		<b>HG18EZ</b>	<b>HG18C</b>
<b>OVERALL DIMENSIONS 1</b> without optional drain tray	inches	25" W x 39" D x 46.5" H	25" W x 39" D x 34" H
	cm	64 x 98 x 118 cm	64 x 98 x 86 cm
<b>OVERALL DIMENSIONS 2</b> with optional drain tray extended	inches	44" W x 39" D x 46.5" H	44" W x 39" D x 34" H
	cm	112 x 98 x 118 cm	112 x 98 x 86 cm
<b>SHIPPING DATA</b> (Approximate, shipped in carton or pallet)	inches	48" x 40" x 42"	48" x 40" x 42"
	cm	122 x 102 x 107cm	122 x 102 x 107cm
	lbs	205 lbs	165 lbs
	kg	93 kg	75 kg
<b>FREIGHT CLASS</b>		250	250

**GLAZING SCREENS (Purchased separately)**

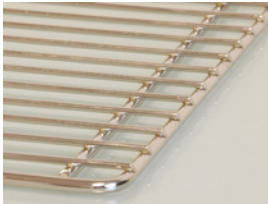
					<b>APPROX. SHIPPING WEIGHT</b> (Carton of 12 screens)
		<b>GLAZER MODEL</b>	<b>PART NUMBER (for GLAZING SCREENS)</b>	<b>SCREEN SIZE</b>	
		HG18EZ	SL200-0004	17" x 25" (43 x 63 cm)	45 lbs (21 kg)
SL200-0004 Glazing Screen (made with high quality nickel plated steel)		<b>FREIGHT CLASS: 70</b> (Screens only)			